

UNDERPINNING

GOLIATH TECH

SCREW PILE SYSTEM



HELICAL PILE SUPPORT SYSTEM FOR FOUNDATION UNDERPINNING



EXCLUSIVE ANCHORING SOLUTIONS

ISO 9001:2015 CERTIFIED | ISO 14001:2015 ENVIRONMENTAL CERTIFIED | ICC-ES ESR-3726
AWS D1.1 / CWB CERTIFIED | CCMC CERTIFIED #13675-R | ACQ & CA COMPLIANT

COMPLETE STRUCTURAL FOUNDATION SUPPORT SOLUTIONS FOR RESIDENTIAL AND COMMERCIAL BUILDINGS

SECURE & ECONOMICAL

GoliathTech screw piles are an innovative new solution for foundation underpinning that is easier, faster and more economical than concrete!

Over time foundations can crack, separate or sink, requiring repair work to preserve the structure it supports. Your home is your most important investment, and ignoring its foundation will put your home at risk!

Foundation rehabilitation often includes underpinning (re-supporting or extending) the foundation in order to strengthen it. In the past this may have required major excavation of the ground around the foundation and re-pouring concrete.



UNDERPINNING BRACKET LIFTS THE FOUNDATION AND THE SUPPORTED STRUCTURE



A GoliathTech helical pile support system will save your home from collapse... affordably!

Offering technological superiority and easy installation, GoliathTech helical piles can be used in any soil and environmental condition, to re-support even the heaviest loads. These specially engineered helical piles are installed quickly and easily under the existing foundation, deep into stable soil — typically 20 to 30 feet — to re-support and elevate the structure. The screw piles remain stable over time and prevent future compromise of the foundation.

EASY INSTALLATION — EVEN IN SMALL SPACES USING ONLY A MINI EXCAVATOR:

- ✓ **PRECISE INSTALLATION ACCORDING TO EACH UNIQUE SITE**
- ✓ **30-YEAR WARRANTY***
- ✓ **ECONOMICAL SOLUTION**
- ✓ **NO WEATHER DELAYS**
- ✓ **FULLY ENGINEERED**

*See detailed warranty information at www.goliathtechpiles.com/warranty/



QUALITY ENGINEERING

- 1 UNDERPINNING BRACKET TO SUPPORT STRUCTURE**
- 2 JACK LIFTS AND LEVELS FOUNDATION**
- 3 MULTIPLE HELIXES OF UP TO 29 INCHES FOR STABILITY**
- 4 GALVANIZING PROCESS PROTECTS STEEL AGAINST CORROSION**

SUPERIOR COMPRESSION HANDLING

- Industry-leading pile compression resistance
- Threaded rods feature high shear capacity
- Specially designed braced underpinning brackets

PRECISE INSTALLATION ACCORDING TO SOIL QUALITY ON SITE... IN 3 STEPS

STEP 1. EVALUATE

Trained installer evaluates foundation and determines level to which it must be raised. On-site soil is also analyzed for its composition.

STEP 2. GAUGE DEPTH

Pressure gauges on our proprietary, calibrated torque-reading equipment determine the exact tension and compression values required to reach stable soil.

STEP 3. INSTALL

GoliathTech helical piles specifically engineered for foundation projects are installed deep into solid earth. These piles are depth-adjustable to reach optimum soil.

JACK LIFTS STRUCTURE

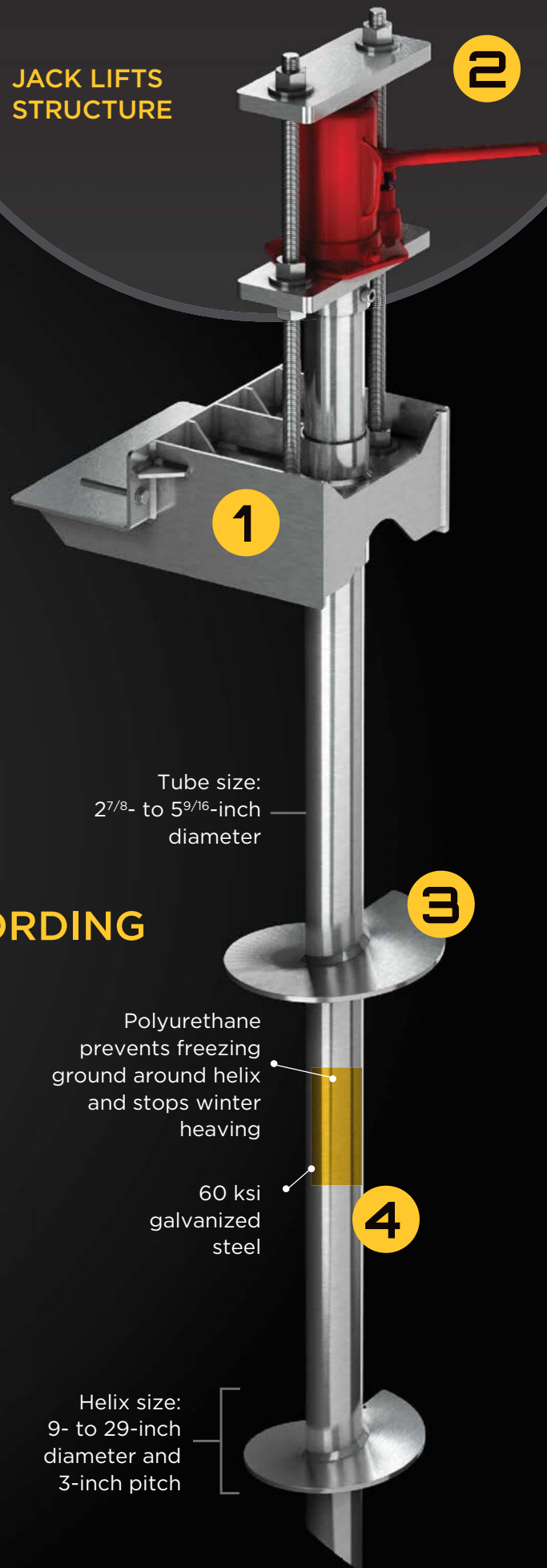



WE ARE GOLIATHTECH

THE PILLARS OF YOUR PROJECTS

For more than 10 years GoliathTech has combined engineering innovation with installation expertise to offer the best helical piling solutions to address sinking structures and underpin foundations, for both commercial and residential applications.

Manufacturer and installer of screw piles, GoliathTech continues to innovate so that our customers around the world benefit from products and service that surpass the highest industry quality standards.

BEST-IN-CLASS ENGINEERING

GoliathTech experts will recommend the right solution to fit your soil characteristics and the required load capacity. The engineering innovation in our screw piles enables us to restore the integrity of your home's foundation, increasing its longevity and giving you peace of mind.

GOLIATHTECH PROMISE

Because the quality of an installation is as important as the quality of the piles, all GoliathTech installers nationwide have received training at our factory and are certified technicians on the installation of our products. Their expertise guarantees optimal anchoring of each pile.

BACKED BY THE GOLIATHTECH PROMISE OF QUALITY, GUARANTEED!

QUITE SIMPLY SUPERIOR.

For more information on our products or to find a certified GoliathTech installer, please contact us:

TOLL FREE: 1.855.743.4777
INFO@GOLIATHTECHPILES.COM

WWW.GOLIATHTECHPILES.COM



CCMC

ACQ

CA